

SHT-3-01-F Fog North-Seeker Use And Maintenance Instructions

Shaanxi Spaceflight the Great Wall M & C Co., Ltd.

No. 169,Jinhua North Road, Xi'an

Telephone: 86-029-82501390

Fax: 86-029-82501150

Zip code: 710032

Website: www.tuoluoyi.com

1.Product use and scope of use

SHT-3-01-F Fog North-Seeker (hereinafter referred to as the product) is mainly used to quickly and independently determine the true north direction.

This document is applicable to the installation, use and maintenance of products.

2. Composition and working principle of products

The product is mainly composed of fiber optic gyroscope, accelerometer circuit, transposition structure control circuit, processor solution circuit and power conversion circuit.

Based on Sagnac effect, the product uses the laser as the light source and uses the fiber to form an annular optical path to measure the optical path difference caused by the rotation of the positive and negative beams with the fiber ring, so as to obtain the angular increment information of the sensitive axis and measure the angular velocity of the earth rotation.

When working, the angular velocity components of the earth rotation at three different positions are measured by the transposition structure, and the azimuth information of the product is calculated according to the measured angular velocity components of the earth rotation. At the same time, the axial inclination data of the product are obtained through the two-axis accelerometer, which can be used to adjust the carrier platform and correct the inclination of the north seeker.

3 .Main technical

3.1 Power supply

- a) Power supply voltage: 9-36Vdc;
- b) Peak power consumption : $\leq 12\text{W}$ 。

3.2 Main technical

3.2.1 Working mode : static.

3.2.2 Preparation time : ≤ 30 s.

3.2.3 North-seeking time : ≤ 3 min.

3.2.4 Measurement range of transverse and longitudinal inclinations : —
 $15^\circ \sim +15^\circ$ 。

3.2.5 Inclination accuracy : $\leq 0.02^\circ$ (1σ)。

3.2.6 North-seeking accuracy : $\leq 0.06^\circ$ (1σ)。

3.2.7 Azimuth measurement range : 0° - 360°

3.2.8 Working latitude (design assurance) : 65° South to 65° North.

3.2.9 Altitude > 4500 meters.

3.2.10 Digital output form : RS-422. Optional RS-232, RS-485 3.2.11

Weight : $\leq 4.5\text{Kg}$

3.2.12 Communication protocol

Digital communication adopts differential RS-422 asynchronous serial full duplex communication mode.

Serial communication takes a byte as the basic transmission unit, the baud rate is 38400bps, a byte transmission effective bits are 10 bits : 1 bit start

bit (logic 0), 8 bit data bit, no parity check, 1 bit stop bit (logic 1).

8-bit data is always low in the front, high in the back. For a multi-byte number, always first pass low byte, then pass high byte.

Table 3 Output data frame format (10 bytes)

Byte No.	Signal name	Measurement range	valid-bit	Definition	Remarks	
0	Char1		8	Frame header	Hexadecimal number AA	
1	Char2		8	Frame header	Hexadecimal number 55	
2	State		8	Status word	0x00	Activating the North Finder
					0x01	Startup is normal. Northfinding can be performed.
					0x02	Looking for North
					0x03	After north seeking, you can find north again
					0x11	Start exception
3、4	Roll	-15°~15°	16	Transverse inclination	Complement, the third byte is the low byte, 1lsb = 0.01 °	
5、6	Pitch	-15°~15°	16	Longitudinal inclination	Complement, the 5th byte is the low byte, 1lsb = 0.01 °	
7、8	Azimuth	0°~360°	16	azimuth angle	No sign number, the 7th byte is the low byte, 1lsb = 0.01 °	
9	Sum		8	Checksum	The check sum is the algebraic sum of all bytes from 2 bytes to 8 bytes, taking the lower 8 bits.	

Table 4 Input command frame format (4 bytes)

Byte No	Signal name	valid-bit	Remarks
0	Char1	8	Hexadecimal number 24
1	Char2	8	Hexadecimal number 4E
2	Char3	8	Hexadecimal number 46
3	Char4	8	Hexadecimal number 2A

3.3 Environmental conditions

3.3.1 Temperature range : -40°C ~ +70°C .

3.3.2 Storage temperature range : $-55^{\circ}\text{C} \sim +70^{\circ}\text{C}$.

3.3.3 Impact: 10g, 11ms, half sine wave,

Direction : Installation direction,

Times : 3.

3.3.4 Vibration: 5Hz \sim 5.5Hz, 25.4mm; 5.5Hz \sim 200Hz, 1.5g (rms)

Direction : Installation direction.

Time : 15min. Cycle times : 3 times.

3.3.5 Damp heat At the temperature of 30°C , 60°C and relative humidity of $(95 \pm 3)\%$, the metal surface should work normally without corrosion and no blistering, wrinkling, cracking or shedding of the protective coating.

3.3.6 Rain:

Rain intensity : 13cm/h, rain time : 1h, rain angle : four sides and top, nozzle diameter : 1mm \sim 2mm.

4. Outer dimensions

The product shape and installation size are shown in Figs. 1 – 4.

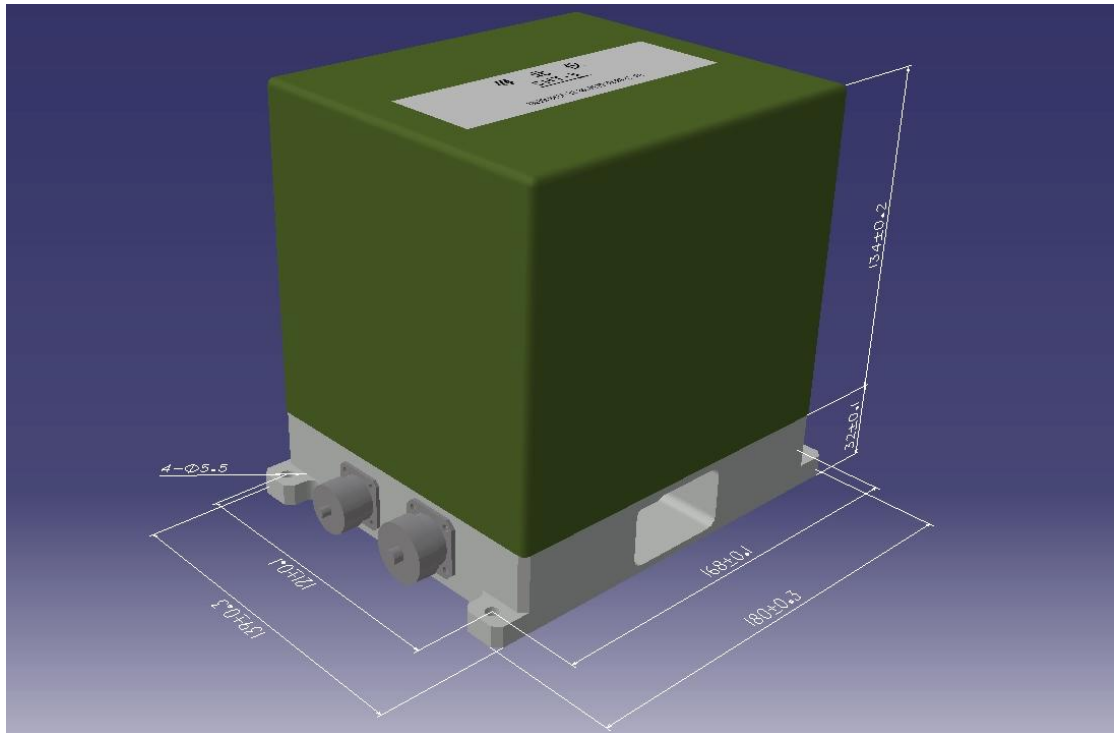

Figure 1 Product left rear view

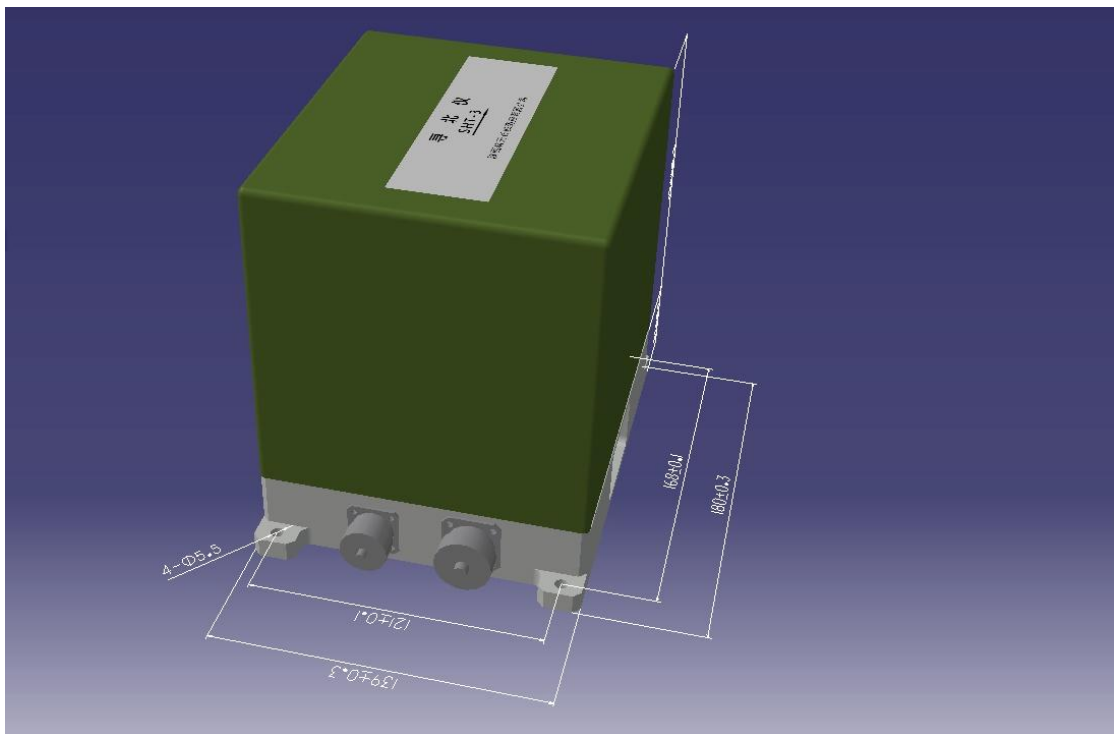

Figure 2 Product left rear view

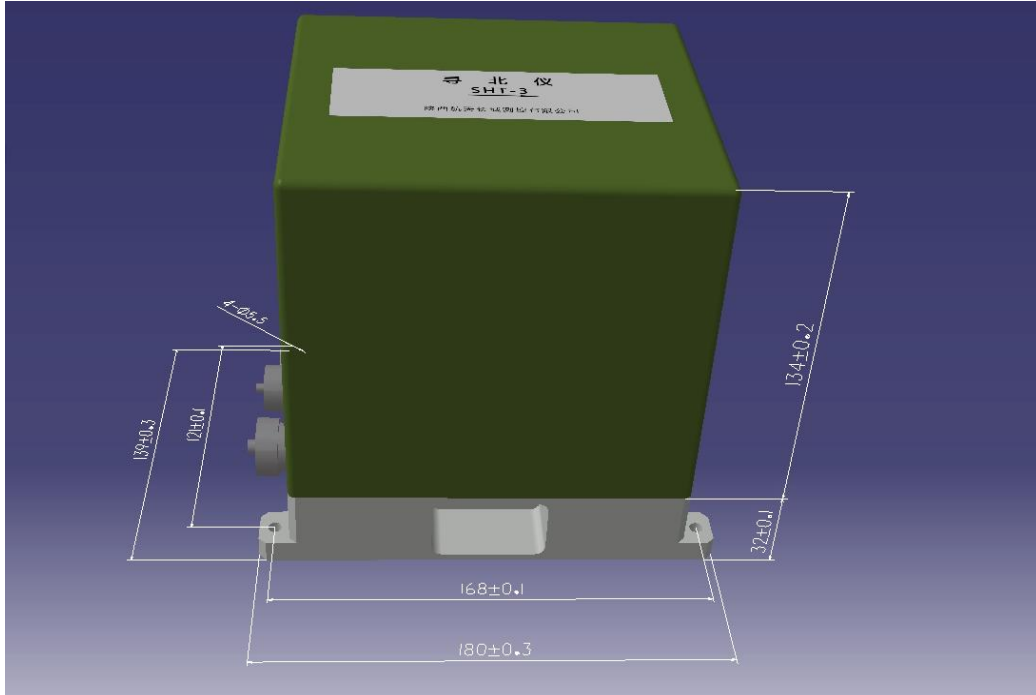

Figure 3 Product perspective

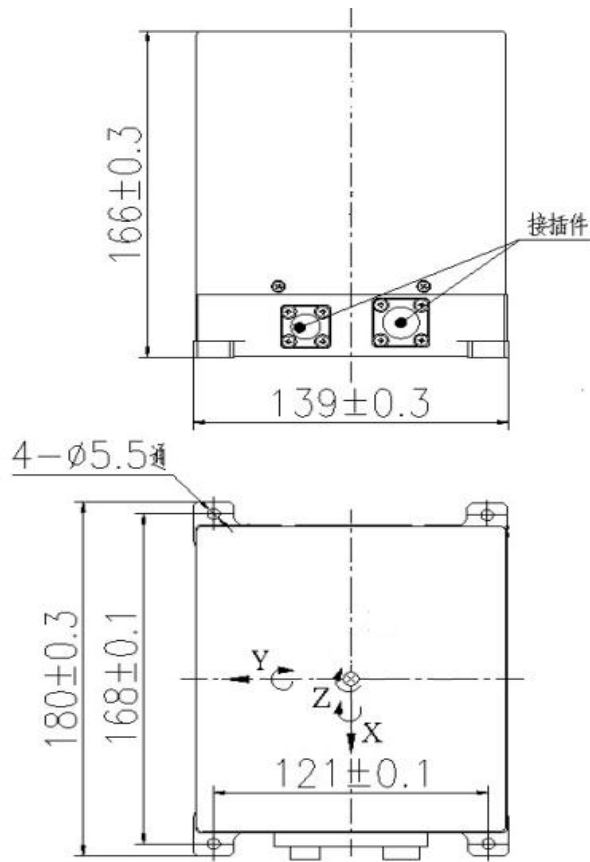

Figure 4 Product bottom installation figure

5 .Axial definition

Transverse angle : X axis parallel to the longitudinal axis of the carrier, pointing to the head of the carrier is positive, according to the right hand rule around the X axis rotation angle corresponding to the transverse angle, left high right low is positive.

Longitudinal angle : Y axis parallel to the transverse axis of the carrier, pointing to the right side is positive, according to the right hand rule around the Y axis rotation angle corresponding to the longitudinal angle, front high back low positive.

Azimuth angle : the angle between the projection of X axis on the horizontal plane and the north direction of geography, corresponding to the rotation angle around Z axis according to the right hand rule, the north is 0 degree and the east is 90 degree.

6. Installation requirements

6.1 Install the product on the carrier datum plane with flatness less than 0.05 mm and tighten the product with screws to ensure rigid connection.

6.2 Ensure the product axial and carrier test axial parallel, overlap.

7 .Interface definition

The external electrical connection connectors are power supply interface Y11X-0804ZJ10 and communication control interface Y11X-1007ZK10.

The interface definition is detailed in table 1 and table 2.

Table 1 Definition of Power Supply Interface

SocketY11S0804ZJ10			Matching plugs	Cable length	Remarks
Core number	Signal	Description	Y11X-0804TK2	> 1m	Clear identification
1	Positive power input	+24V			
2	power earthing				
3	EGND	Shell			
4	NC	nc			

Table 2 Communication Control Interface

SocketY11S1007ZK10			Matching plugs	Cable length	Remarks
Core number	Signal	Description	Y11X-1007TJ2	> 1m	Clear identification
1	RS-422:TX+	Signal output from product to external terminal			
2	RS-422:TX-				
3	RS-422:RX+	Signal input from external terminal to product			
4	RS-422:RX-				
5	NC	Factory use, not connected			
6	NC	Factory use, not connected			
7	NC	Factory use, not connected			

8. Rules of use and operation

8.1 This product is a precision instrument and requires light handling and light release.

8.2 This product requires power supply strictly according to product instructions, otherwise it will cause permanent damage.

8.3 The use of this product has its particularity. Operators must first understand the use instructions of the product in detail.

8.4 Maximum eigenvalue of product work :

Shock : 10g, 8ms-12ms.

Working temperature : -40 °C ~ + 70 °C.

Storage temperature : -45 °C ~ + 70 °C.

If used more than the maximum eigenvalue will cause permanent damage to the product.

8.5 Users should adjust the level of the worktable according to the X, Y axis inclination before the formal north search, so that the product can meet the requirements of its working environment. In the process of product north-seeking, the carrier should be in a static state and disturbance interference should be avoided.

8.6 In the installation process, it should be taken and released lightly, and the collision and knock strictly prohibited from collision and knocking.

8.7 Product in the use of the process is strictly forbidden to pull, plug.

8.8 Short circuit between external circuits is strictly prohibited in the use of products.

8.9 Products shall not be squeezed, bumped or smashed during transportation.

8.10 The storage and storage of products should be isolated from corrosive substances such as acid and alkali.

8.11 If an exception occurs in the course of use, the test equipment and product power supply should be disconnected immediately, the causes should be analyzed and corresponding measures should be taken according to the actual situation. If it is a product internal failure, please do not open the product mask without authorization, should notify our company to organize the repair.